



Super Anchor System

Optimum equipment
for flat components



PFEIFER



PFEIFER Super Anchor System

The optimised and safe lifting anchor system for your thin-walled but nevertheless heavy precast concrete units.

With regard to products where safety is an important factor PFEIFER as a German medium-sized company stands for:

- Meticulous product design by our team of engineers
- The use of high quality, reliable materials
- Manufacturing with modern machinery in Memmingen
- Employees whose many years of experience count
- A high degree of repeating accuracy due to electronic control
- Quality management with certificates

Your safety is more important than saving pennies!



| Table of contents | Page |
|-------------------------------------|------|
| Super Waved Anchor | 5 |
| Super Lifter | 9 |
| Accessories for Super Anchor System | 13 |
| Enquiry / order form | 15 |



Suitability for thin wall units



- Reduced socket diameter makes it easier to install the anchor
- Easier to install into dense reinforcements with limited space.
- Optimum anchoring with low splitting effect due to the waves which have proved itself millions of times.

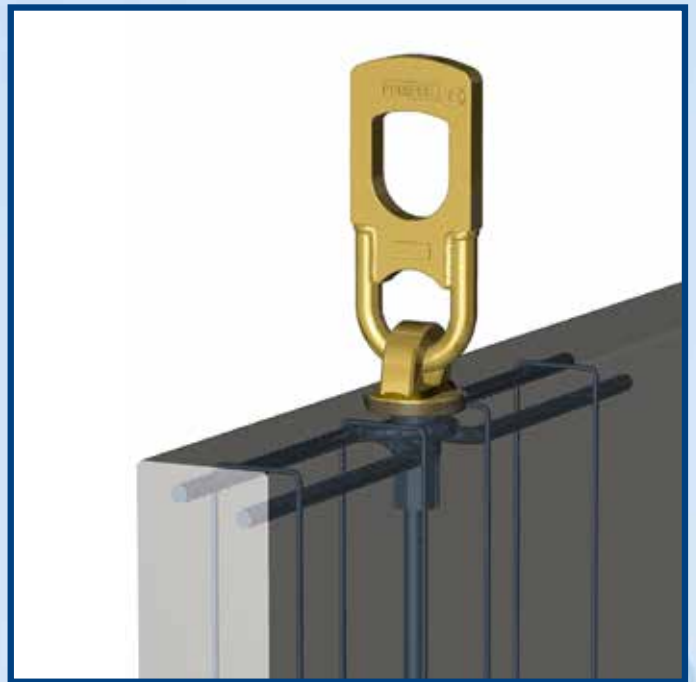

High performance



- Considerably higher load capacity due to the use of high-tensile and ductile steel.
- Up to 45% lower wall thicknesses with comparable load levels.
- Special thread with reduced screwing time.



Unmistakable



- Due to the use of a special thread it is not possible to mistake this system for traditional thread systems.
- The new special thread reliably prevents the thread being confused with traditional threads. It is impossible to screw in customary lifting devices.

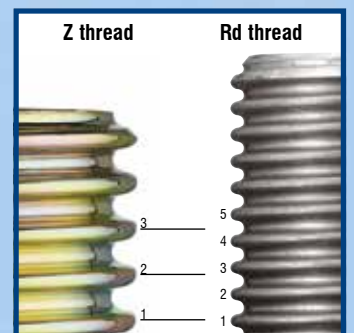

“slim” system – only 3 sizes



- 3 anchor sizes cover load capacities between 0 and 220 kN
- Now only 3 different anchor sizes which makes managing easier and reduces inventory costs.

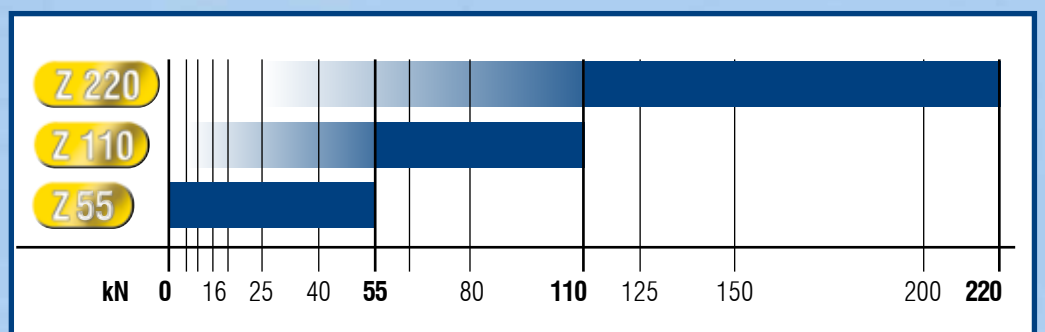

Z 220

Z 110

Z 55

PFEIFER Super Waved Anchor The new superlative for lifting concrete wall elements safely

So slim



- Reduced socket diameter compared to the traditional thread system.
- Even fits when there is a restricted reinforcement guide.
- Sockets are significantly shorter.

So thin



- For wall units that are extremely thin but nevertheless heavy, the long waved bar is designed with a minimal splitting effect.

So strong



- High load capacity due to the special socket construction with a thick wall but a smaller thread.

So safe



- Impossible to mistake this thread with traditional threads. The special Z thread makes incorrect use impossible. Other threads cannot be twisted in.
- Marking on the front allows safe and fast identification, even when casted in.



So fast



- A shorter inner thread and a greater inclination reduce screw-in time significantly.

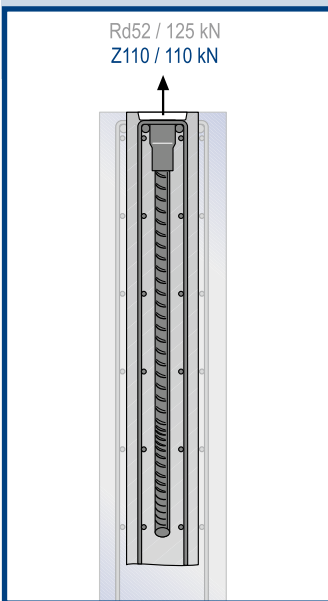

PFEIFER Super Waved Anchor

Article no. 05.090



PFEIFER

Super Anchor System
Lifting anchor

The PFEIFER Super Waved Anchor is an optimised lifting anchor for transporting light-section precast concrete elements. Only three load ranges are required to cover tension forces up to 220 kN.

The reduced socket diameter and the special thread allows now the application in very slim precast wall elements.

Economic efficiency is increased due to significantly higher load capacity and less screwing.

Materials:

Thread socket made of steel zinc-plated, chromated.

Reinforcement steel BSt 500 S, black

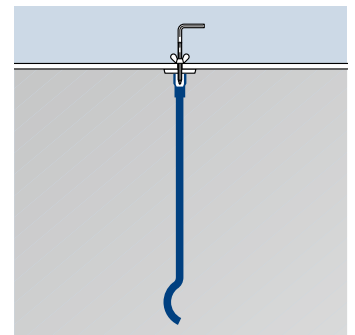
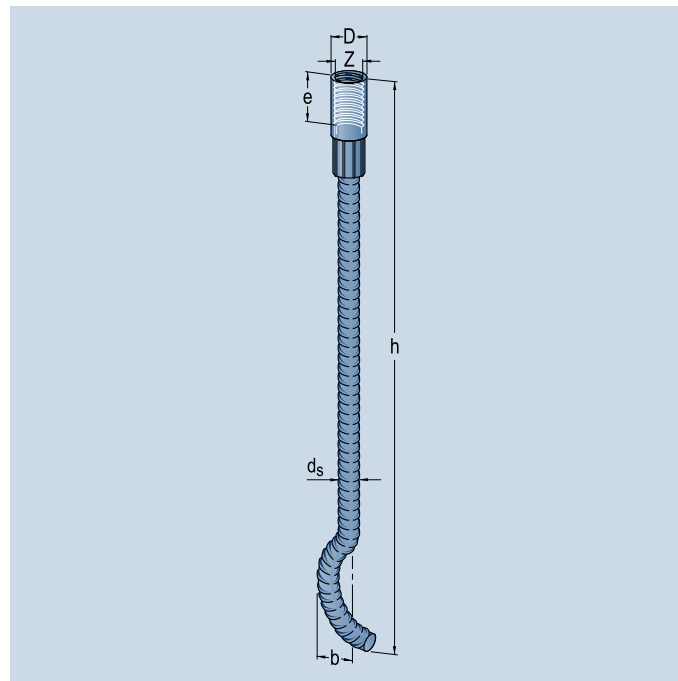

| Ref. No. | Type | maximum load capacity [t] | concrete compressive strength [N/mm ²] | Adm. F _Z | | | Dimensions | | | | | Packing unit (PU) [Qty.] | Weight approx. [Kg/PU] |
|--------------|------|---------------------------|--|---------------------|--------------|--------------|------------|--------|---------------------|--------|--------|--------------------------|------------------------|
| | | | | 0°-15° [kN] | 15°-45° [kN] | 0°-90°* [kN] | D [mm] | b [mm] | d _s [mm] | e [mm] | h [mm] | | |
| 05.090.055.3 | Z55 | 5,5 | 15 | 55 | 30 | 11 | 36 | 40 | 20 | 35 | 680 | 10 | 20,6 |
| | | | 30 | 55 | 30 | 15 | | | | | | | |
| 05.090.110.3 | Z110 | 11,0 | 15 | 110 | 70 | 17 | 55 | 50 | 28 | 50 | 890 | 4 | 21,0 |
| | | | 30 | 110 | 70 | 22 | | | | | | | |
| 05.090.220.3 | Z220 | 22,0 | 15 | 220 | 110 | 31 | 70 | 40 | 40 | 60 | 1300 | 1 | 14,5 |
| | | | 30 | 220 | 110 | 44 | | | | | | | |

(Note: 10 kN = 10 kilonewton = weight force of a mass of 1.0 t)

Adm. F_Z: Admissible force during straight pull

Adm. F_S: Admissible force during parallel shear pull

Adm. F_Q: Admissible force during transversal pull

* Special case tilting table look at page 7

Example of an order for PFEIFER Super Waved Anchor, galvanized with 110 kN or 11 t maximum load capacity:
50 PFEIFER Super Waved Anchor order no. 05.090.110.3

Installation Instructions for PFEIFER Super Waved Anchor

1. Reinforcement

PFEIFER Super Waved Anchors can be used upward of a concrete strength of 15 N/mm^2 and a minimum surface reinforcement according to Table 1. In the vicinity of the anchor socket, an additional minimum reinforcement, comprising two continuous iron edge rods and four loop strap inserts must be installed.

The anchor rod made from BSt 500 S, which is swaged with the reinforced threaded socket, leads the local forces into the precast concrete element. The designer is responsible for the further distribution of the forces and stresses in the precast element.

When using angled tensioning for $\beta > 0^\circ$, one or two angle-tension loop straps are required as shown in Fig. 4. For transverse shear pull, a special reinforcement should be installed as shown in Fig. 7. For simultaneous angled and transverse pulling, a combination as shown in Fig. 6 should be employed.

Table 1: Minimum reinforcement

| anchor type | edge straps | | insert straps | | | minimum surface reinforcement [mm ²] |
|-------------|-------------|------------|---------------|--------|--------|--|
| | d_s [mm] | d_s [mm] | L [mm] | a [mm] | b [mm] | |
| Z55 | 12 | 8 | 500 | 50 | 100 | Q 188 A |
| Z110 | 12 | 8 | 640 | 50 | 100 | Q 188 A |
| Z220 | 16 | 12 | 900 | 70 | 100 | Q 257 A |

Fig. 1: Minimum round steel reinforcement "central tensioning"

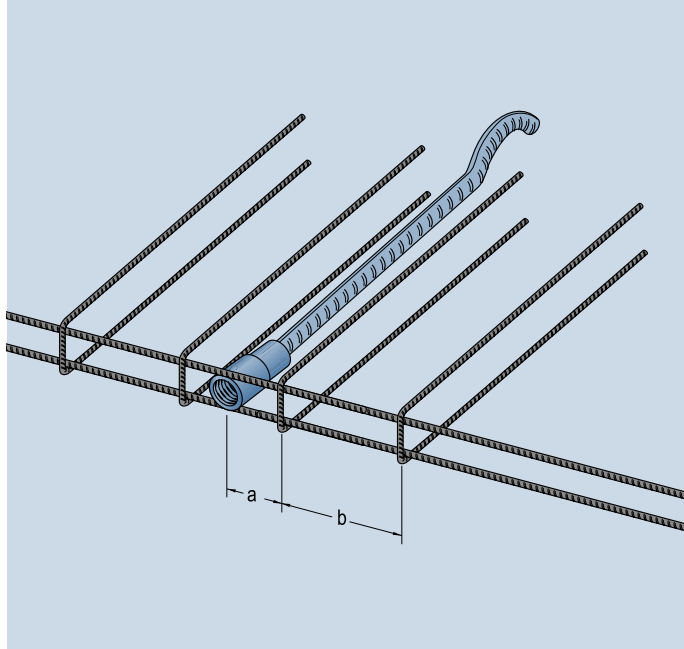

2. Minimum dimensions

In order to guarantee the local load distribution in the concrete, specific edge and axis distances between the lifting anchors and the free edge must be complied with. For safety reasons, the slab thickness of the precast element in the anchor area must also have a certain minimum material thickness (Fig. 2). The minimum thickness values applying to the Super Waved Anchor are listed in Table 2.

Table 2: Minimum dimensions

| anchor type | distance to edge | axis distance | minimum slab thickness |
|-------------|------------------|---------------|------------------------|
| | a [mm] | b [mm] | d [mm] |
| Z55 | 900 | 1800 | 120 |
| Z110 | 1100 | 2200 | 160 |
| Z220 | 1400 | 2800 | 220 |

Fig. 2: Minimum dimensions of the construction element

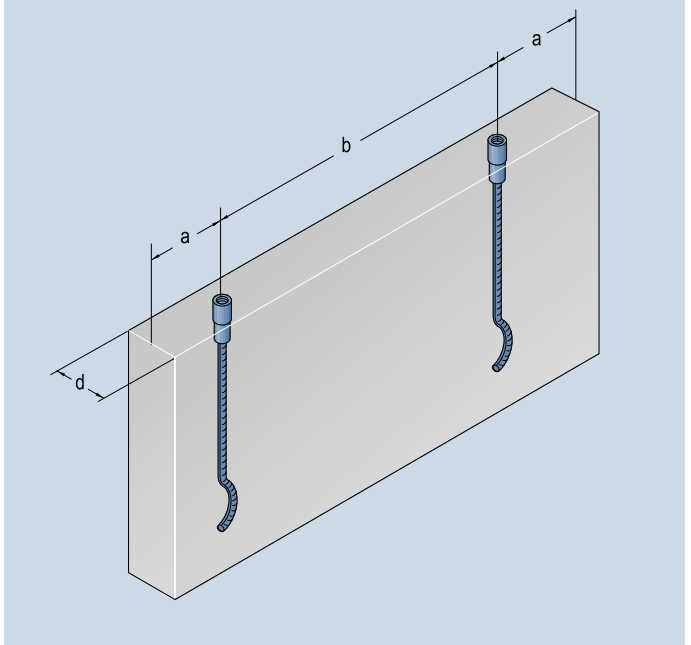

3. Parallel shear reinforcement

If the PFEIFER Super Waved Anchors are loaded during transport parallel shear pull in the plane of the slab ($\beta > 0^\circ$) the additional horizontal forces must be absorbed (Fig. 3). For this reason a parallel shear reinforcement must be installed in the direction opposite to the direction of the force, and in direct contact to the socket as shown in Table 3., Fig. 5.

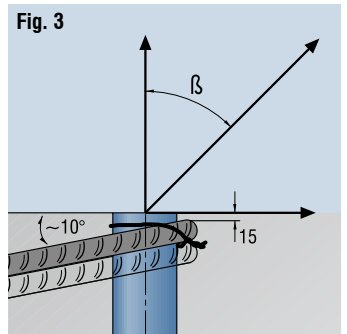
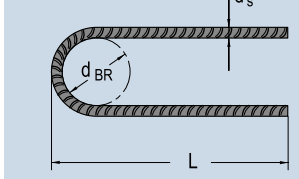

Fig. 3

Table 3: Parallel shear reinforcement

| anchor size type | parallel shear reinforcement | | |
|------------------|------------------------------|--------|---------------|
| | d_s [mm] | L [mm] | d_{BR} [mm] |
| Z55 | 10 | 750 | 40 |
| Z110 | 14 | 1000 | 60 |
| Z220 | 2x16 | 1200 | 80 |

Fig. 4: Parallel shear reinforcement BSt 500 S



Because of the small bending diameter, the parallel shear reinforcement should be checked before installation for cracks due to bending of the concrete reinforcement steel.

Fig. 5: Additional reinforcement "parallel shear pull in the plane of the slab"

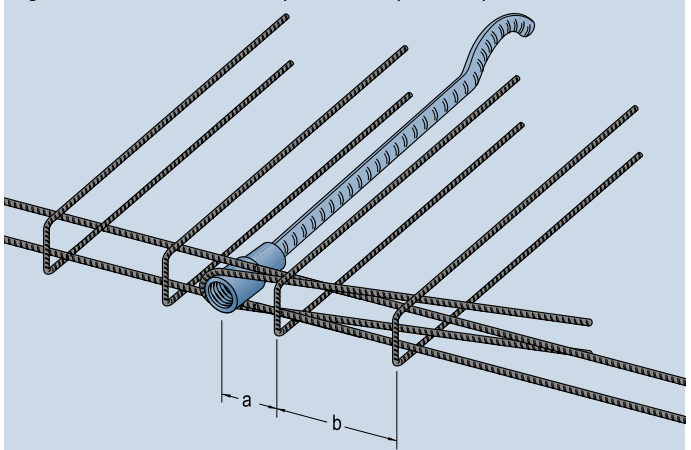

4. Transversal shear pull

The PFEIFER waved anchor is designed to be accommodated in the front side of thin concrete slabs. They can be used both for lifting the horizontally-lying concrete wall slabs and also for vertical transport.

When the concrete elements are lifted into a vertical position, a transverse force develops with a force angle to the plane of the slab of 90° . The transverse force acting on the near, free edge has a strong effect, particularly for thin precast slabs, and for this reason the lifting anchors must be installed with a back hanging or transversal shear reinforcement. As a result of this transversal shear reinforcement, the transverse force components can be back hung and safely inserted into thin concrete elements. The transversal shear reinforcement is specifically designed for these elements and always comprises two hat-shaped bent back hanging pins, which must be installed in addition to the minimum reinforcement required (Fig. 6).

Fig. 6: Additional reinforcement for “combined parallel shear and transversal shear” or “transversal shear” – symmetrical transverse shear reinforcement

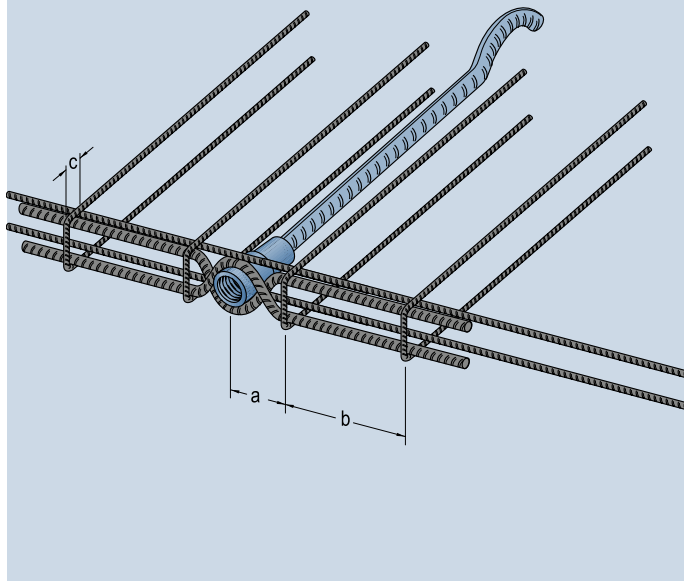

When installing the transversal shear reinforcement, it is necessary to ensure a direct contact between the back hanging pins and the anchor socket. To this end the back hanging pin can be spotted to the socket. Furthermore, a symmetrical, transverse shear reinforcement should always be installed (Fig. 6). This saves having to mark the precast elements prior to transport. Since the precast elements will be unloaded and restacked a number of times during transport, this second back hanging pin should generally be inserted to cover the opposite force direction of the transverse pull direction. This means that there is no unnecessary safety risk even for very thin slabs.

Table 4: Additional transversal shear reinforcement

| anchor size type | back hanging pin position 1 | | | | |
|------------------|-----------------------------|--------|---------------|------------|--------|
| | d_{s1} [mm] | L [mm] | d_{br} [mm] | h_1 [mm] | c [mm] |
| Z55 | 12 | 570 | 58 | 64 | 50 |
| Z110 | 16 | 780 | 64 | 86 | 50 |
| Z220 | 20 | 1040 | 80 | 112 | 70 |

Fig. 7: Transverse shear reinforcement BSt 500 S

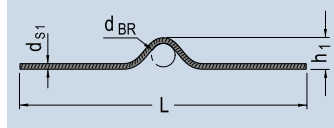

Because of the small bending diameter, the transversal shear reinforcement should be checked before installation for cracks due to bending of the concrete reinforcement steel.

The components of the transverse shear reinforcement shown in Fig. 6 are specifically designed for use with very thin precast element thicknesses. If the available construction component thickness is greater than the minimum slab thickness d , given in Table 2, the height of the back hanging pin (dimension h_1) can be selected proportionally higher. This simplifies installation and improves force distribution.

5. Admissible Force for transverse, parallel shear and combined loading

For simultaneously operating parallel shear and transversal shear, for example as in the case of lifting a precast wall element into an upright position (Fig. 8), only the symmetrical transverse shear reinforcements (Fig. 6), which also cover the parallel shear, need be installed. A additional parallel shear reinforcement as shown in Fig. 4 is not required.

Special case: lifting from tilting table

A tilting table is used to lift the precast slabs into an upright position. Then the angle of the force to the vertical is often smaller than $\gamma = 15^\circ$. In this case exceptionally the adm. load F_Z can be taken into account. The symmetrical transverse shear reinforcement has to be installed.

For angled tensioning ($15^\circ \leq \beta \leq 45^\circ$) in the plane of the precast concrete slabs, the reduced parallel shear load capacity perm. F_S should be used for all force angles.

For transverse force, the permitted transverse shear force perm. F_Q should be taken into account for the Super Anchors.

Since, during the lifting of the concrete elements to an upright position, one edge of the precast element always has contact with the ground, the anchors for transport in the vertical position will only experience 50% of the force (Fig. 8).

Fig. 8: Force diagram for parallel shear in combination with transversal pull

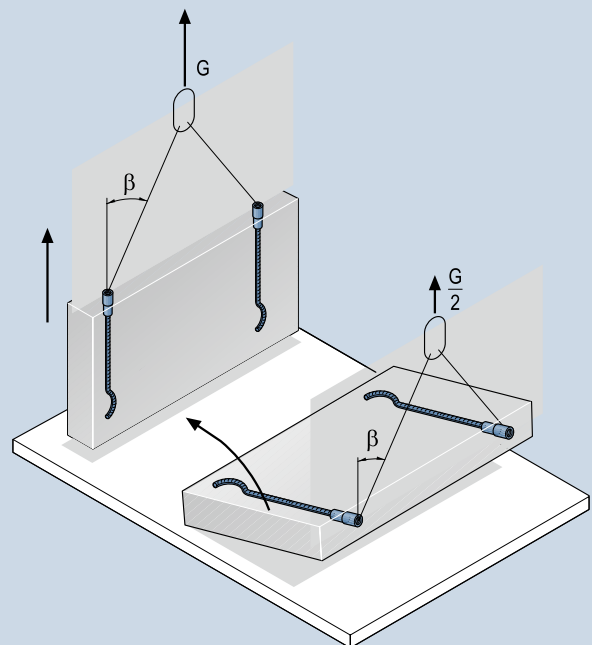
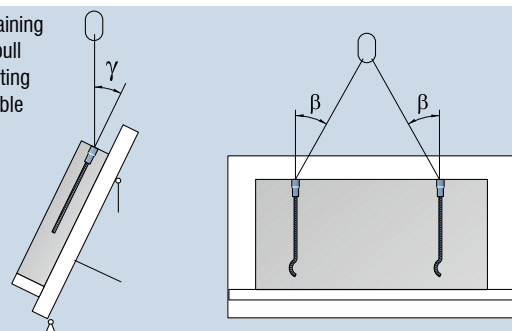

Fig. 9: Remaining transversal pull during the lifting of a tilting table



A comparative example

Z 110

Rd 52

Up to
110 kN

Up to
125 kN

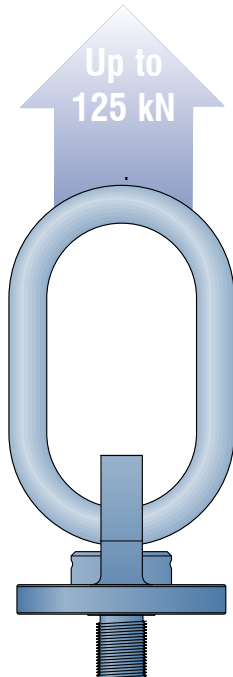

PFEIFER Super Lifter No other system has ever been as efficient!

So easy to handle



- The short thread with large increase allows fast screwing and unscrewing.
- Considerable reduction of dimensions and weight makes handling easier for workers

So strong



- Special steel allows greater load capacities with significantly lower dimensions.

| Type | Load capacity | Weight | Type | Load capacity | Weight |
|------|---------------|---------|-------|---------------|---------|
| Z55 | 55 kN | 3,6 kg | Rd 36 | 61,5 kN | 5,5 kg |
| Z110 | 110 kN | 10,1 kg | Rd 52 | 125,0 kN | 13,2 kg |
| Z220 | 220 kN | 19,9 kg | Rd 60 | 200,0 kN | 39,0 kg |

So safe



- The shorter thread is faster to screw in completely.
- Screwing in traditional lifting devices mistakenly is completely impossible due to different thread formation.
- Sturdy round thread prevents difficult screw-turning due to dirt or damage.

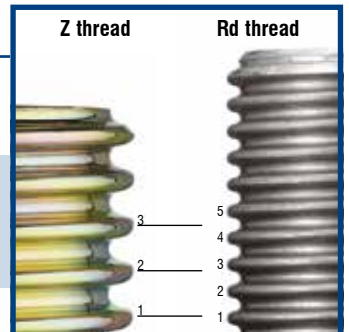

Z 220



PFEIFER Super Lifter

Article no. 05.092



PFEIFER

Super Anchor System
Lifting devices

As a lifting device in the Super Anchor System the PFEIFER Super Lifter offers the possibility of attaching the Super Waved Anchor securely even with low wall thicknesses.

The pressure plate distributes the load considerably better, particularly with parallel shear pull and transversal pull

Due to the use of a special thread it is not possible to mistake this system for traditional thread systems. The use of special material and insensible thread a long-life-cycle is secured.

Materials:

Steel, zinc-plated, chromated
Very strong threaded bolts

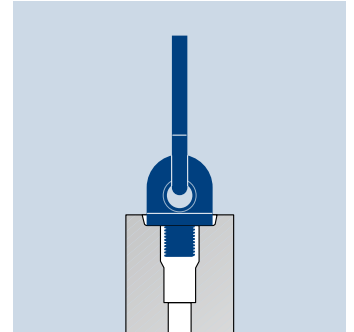
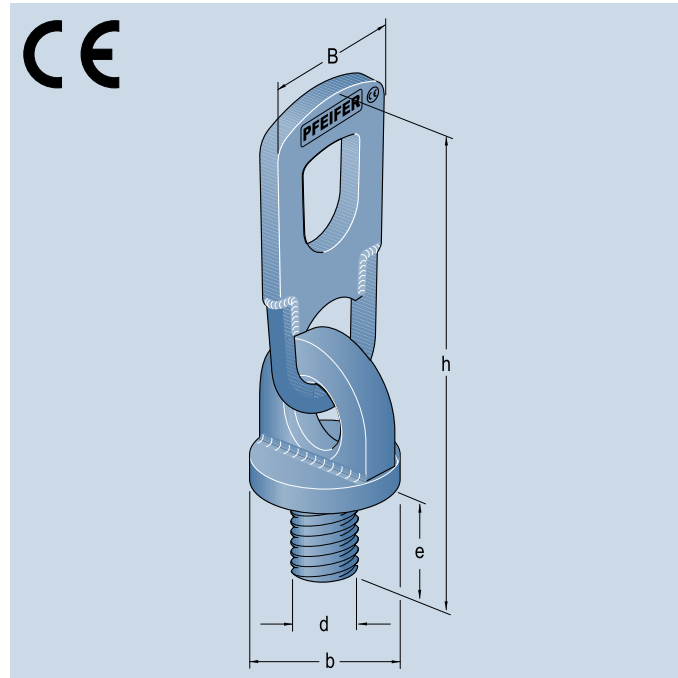

| Order no. | Type Size | Max. F [KN] | Maximum load capacity [t] | Dimensions | | | | | Packing units (PU) [Qty.] | Weight approx. (kg/PU) |
|--------------|-----------|----------------|------------------------------|------------|-----------|-----------|-----------|-----------|------------------------------|---------------------------|
| | | | | B [mm] | b [mm] | d [mm] | e [mm] | h [mm] | | |
| 05.092.055.1 | Z55 | 55 | 5,5 | 118 | 80 | 22 | 35 | 300 | 1 | 3,8 |
| 05.092.110.1 | Z110 | 110 | 11 | 160 | 110 | 32 | 50 | 440 | 1 | 10,1 |
| 05.092.220.1 | Z220 | 220 | 22 | 186 | 120 | 48 | 60 | 545 | 1 | 19,9 |

(Note: 10 kN = 10 kilonewton = weight force of a mass of 1 t)

Example of an order for PFEIFER Super Lifter, with 110 kN or 11 t maximum load capacity:
10 PFEIFER Super Lifters order no. 05.092.110.1

Application instructions for PFEIFER Super Lifters

1. Construction

The PFEIFER Super Lifter is a special construction especially for the high forces with lower component dimensions and with a force contact angle of 90°. Increased requirements also occur, however, when erecting precast concrete units and when there is parallel shear pull of over 45°.

These demands are taken into account with sensible dimensioning of the cross-sections with the pressure plate, a high-tensile and ductile weldable thread bolt in combination with the PFEIFER Z thread as well as the lifter's handle made of sturdy cast steel.

2. Labelling

PFEIFER Super Lifters are clearly and legibly (Fig. 1) labelled on the lifter's handle as follows:

| | |
|---------------------------|--|
| Manufacturer | PFEIFER |
| Type/Size / Load capacity | Z220 / max. 22t |
| Year of manufacture | 04 |
| Batch number | Number knocked in for the purpose of identifying the batch |

PFEIFER Super Lifters fit exclusively into the PFEIFER Super Anchor System with the specified load level. There is no danger of making a mistake. They may only be used for this designated purpose.



The maximum load capacity of the lifter is calculated by the anchor failure in the concrete. The load capacity is reduced during parallel shear pull and transversal pull.

Fig. 1: Labelling

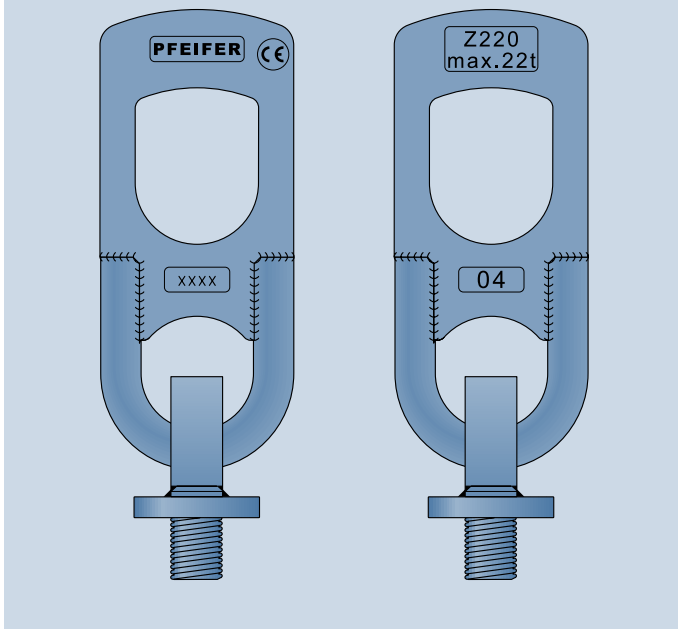

3. Handling and Functioning

The PFEIFER-Super Lifter must be completely screwed into the thread of the Super Waved Anchor so that the pressure plate of the rotary lifter lies completely flatly on the concrete. Due to its reduced weight, the lifter can be easily twisted by hand on the lifter's eye into the Z thread. The Super Lifter should be twisted fully into the lifter's opening. The lifter's eye and the lifter's body are then ready to operate aligned in the direction of force (Fig. 2).

Fig. 2

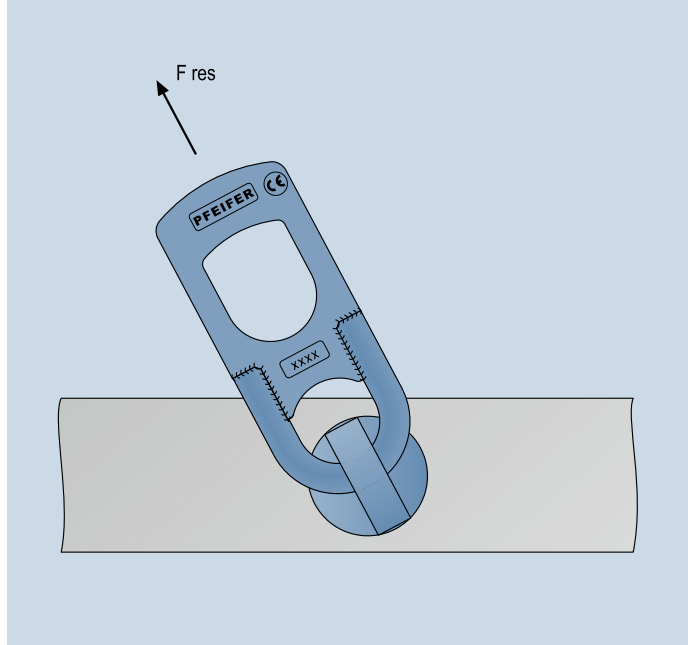
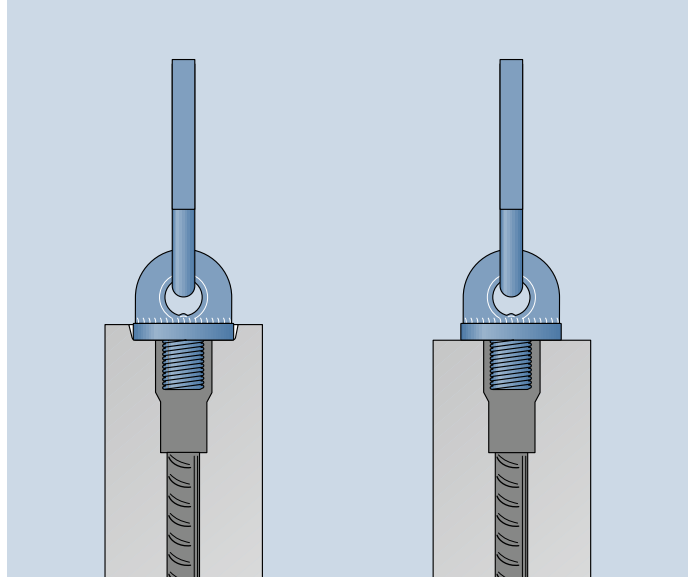

Fig. 3: Fitting the Super Lifter

... in recessed anchor installation – in flush anchor installation



For this, the Super Lifter may be twisted back by a maximum of half a rotation.

If the PFEIFER-Super Lifter is screwed in up to the top edge of the Super Waved Anchor the whole length of the thread is then available for the force induction. Cavities between the top edge of the Super Waved Anchor and the bottom edge of the PFEIFER Super Lifter can be ruled out (Fig. 3). If the pressure plate is not lying completely flatly or the bolt is running free for a certain length, there is a danger of the threaded bolt breaking off due to alternating stress during bending. For this reason you should use the PFEIFER accessories for the installing the PFEIFER Super Waved Anchor into the formwork in order for the anchor to be installed exactly vertically, flush to the surface of the concrete. Otherwise there is neither a guarantee that the pressure plate can be fitted into the opening during recessed installation nor that it can be laid onto the even concrete (Fig. 3)

4. Maintenance

The PFEIFER Super Lifter itself is maintenance-free. However, attention should be paid that threaded bolt, pressure plate and the interior of the lifter remain free of dirt and residual concrete. Any dirt or residual concrete that is attached here has to be removed. Gentle lubrication with oil prevents corrosion and makes the twisting in and out process easier. The Super Lifter is not suitable for being kept outside permanently for corrosion reasons.

5. Discarding time and monitoring of use

PFEIFER Super Lifters are lifting devices. According to the valid regulations they are to be inspected and checked by an expert before using for the first time and, once in operation, they should be checked once a year visually to see if there is any damage or if it is time for it to be discarded.

For this reason, PFEIFER offers a proper inspection in a mobile testing laboratory. An appointment having been arranged, this testing vehicle then comes to you in your factory. Any dirt or oil should be cleaned off the Super Lifters beforehand. The check includes detecting any external faults, deformations, initial cracking and erosion.

If the thread path is damaged or torn out or the threaded bolts and/or the pressure plate is deformed then the Super Lifter should be discarded.

Super Lifters in which the thickness of the material has worn away by more than 10% in any place (Fig. 5) or in which there has been a lengthening or necking due to overstrain or wear and tear (Fig. 4) are to be withdrawn from operation immediately.

An expert should perform an inspection, as described above, after exceptional loads or cases of damage which could have an effect on the load capacity.

Super Lifters which are exposed to temperatures of over 250°C should be discarded.

Table 1: Dimensions of the lifter body

| Super Lifter | Readiness for discarding d_k [mm] | Nominal diameter d [mm] |
|--------------|-------------------------------------|---------------------------|
| Z55 | 40 | 22 |
| Z110 | 52 | 30 |
| Z 220 | 75 | 40 |

Fig. 4: Suitability for discarding in the case of deformations

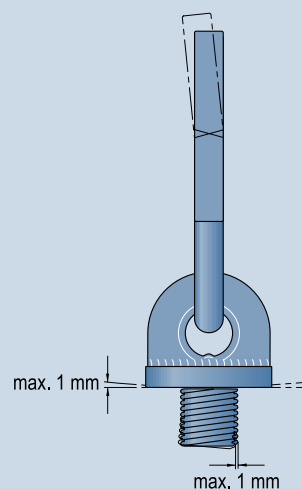
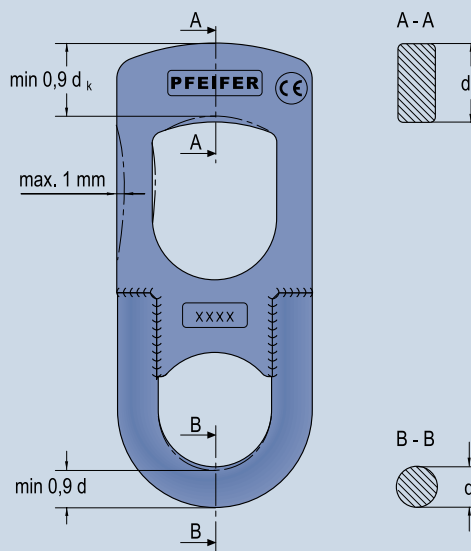

Fig. 5: Suitability for discarding in the case of material erosion



Please note:

These instructions relate to specific articles. In addition, attention should be paid to the General, technical introduction for PFEIFER Lifting anchor systems.”

The PFEIFER Super Lifter is an integral part of the Super Anchor System. It has been officially tested and corresponds to the EC guidelines for machinery.

PFEIFER Accessories for formwork So that the Super Waved Anchor fits fantastically!

So adaptable



- The fixing screw fits each board thickness in a matter of seconds and always holds extremely securely without a screw wrench. Only a small hole in the formwork is necessary.

So precise



- With a fixing bolt, recess disc and fixing screw the Super Waved Anchor fits extremely securely and is precisely right-angled to the formwork

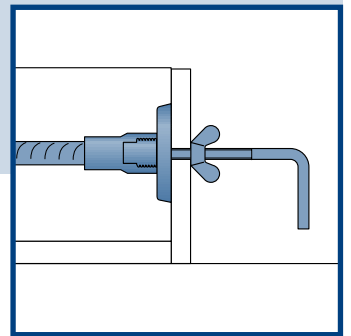

So well coordinated



- The Super Lifter fits exactly in the opening of the precast unit.

So flexible



- It is not only possible to screw through the formwork but also to nail onto wooden formwork.

So well covered



- Finally, the external cap completely covers the thread and the seating of the recess disc optically and presents an architecturally neat and elegant view.



Accessories PFEIFER-Super Anchor System

PFEIFER Fixing bolt

Article no. 05.094

PFEIFER Recess disc

Article no. 05.096

PFEIFER Fixing screw

Article no. 05.206

PFEIFER external cap

Article no. 05.098



PFEIFER

Super Anchor System
Formwork accessories

The PFEIFER recess discs are intended for recessed anchor installation. A horizontal even surface for the lifter's pressure plate that is right-angled to the lifting anchor's longitudinal axis can only be reached with PFEIFER recess discs.

The PFEIFER fixing bolt is used to evenly fix the PFEIFER-Super Waved Anchor on the formwork as well as for recessed installation.

It forms the link between the metric thread and the Z thread of the PFEIFER-Super Waved Anchor.

After the precast unit has been assembled the recessing can be closed with the PFEIFER external cap flush to the surface.

Materials:

Steel, zinc-plated, chromated

External cap in stainless steel on request

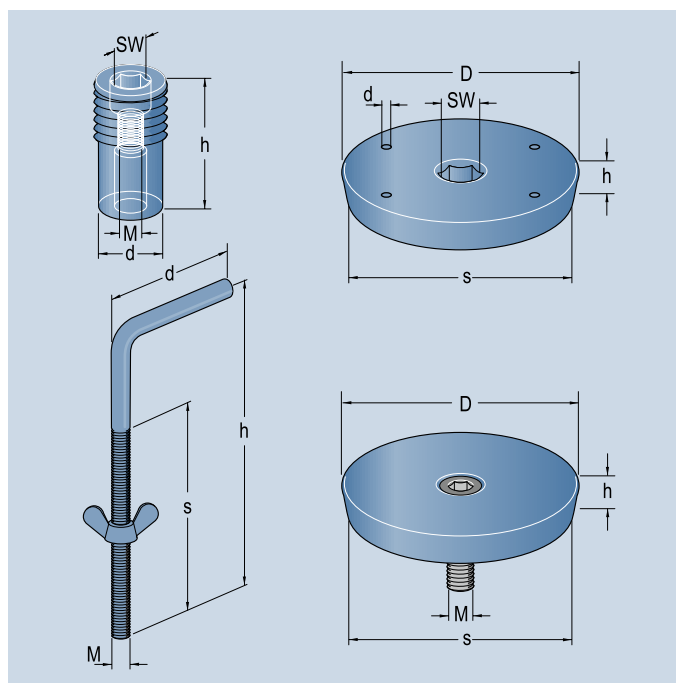

| Order no | Type Size | SW | Dimensions | | | | M | Packing unit (PU) [[Qty.] | Weight approx. [kg/PU] |
|---------------------|-----------|----|------------|--------|--------|--------|-----|---------------------------|------------------------|
| | | | h [mm] | D [mm] | d [mm] | s [mm] | | | |
| Fixing bolt | | | | | | | | | |
| 05.094.055.3 | Z55 | 8 | 33 | - | 18 | - | M8 | 10 | 0,60 |
| 05.094.110.3 | Z110 | 14 | 48 | - | 28 | - | M10 | 10 | 1,8 |
| 05.094.220.3 | Z220 | 14 | 58 | - | 41 | - | M10 | 10 | 6,0 |
| External cap | | | | | | | | | |
| 05.098.055.3 | Z55 | - | 20 | 89 | - | 82 | M8 | 10 | 7,0 |
| 05.098.110.3 | Z110 | - | 20 | 118 | - | 112 | M10 | 10 | 16,0 |
| 05.098.220.3 | Z220 | - | 20 | 128,9 | - | 122 | M10 | 10 | 17,0 |
| Recess disc | | | | | | | | | |
| 05.096.055.3 | Z55 | 10 | 20 | 89 | 4 | 82 | - | 10 | 7,0 |
| 05.096.110.3 | Z110 | 14 | 20 | 118 | 4 | 112 | - | 10 | 16,0 |
| 05.096.220.3 | Z220 | 14 | 20 | 128,9 | 5 | 122 | - | 10 | 17,0 |
| Fixing screw | | | | | | | | | |
| 05.206.083 | Z55 | - | 120 | - | 60 | 80 | M8 | 100 | 11,00 |
| 05.206.103 | Z110/Z220 | - | 180 | - | 60 | 150 | M10 | 100 | 19,00 |

Example of an order for 50 PFEIFER fixing screws for fixing Z fixing bolt, suitable for Z60:

50 PFEIFER fixing screws order no. 05.206.083

Please order many times the amount of the packing unit (cardboard box)!

Installation instructions for

PFEIFER Fixing Bolt

PFEIFER Recess Disc

PFEIFER Fixing Screw

PFEIFER External Cap

Specially matching accessories which can be used in various combinations for different application purposes have been developed for the installation of the PFEIFER-Super Anchor System. The PFEIFER Recess Disc and the PFEIFER fixing bolt are used for formwork installation whilst the PFEIFER External Cap together with the PFEIFER Fixing Bolt make it possible to close the anchor opening flush to the surface.

There are two possibilities for formwork installation:

Fig. 1: Recessed installation

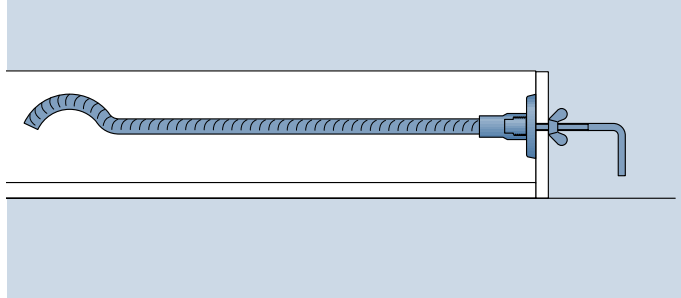

• **Recessed installation (Fig. 1)**

The PFEIFER Recess Discs are fixed to the formwork for the recessed installation of the PFEIFER Super Waved Anchor with the PFEIFER Fixing Bolt (Fig. 1). The fixing bolt allows safe and very fast fixing to formworks of different thicknesses. When a soft wooden formwork is combined with a larger PFEIFER-Super Anchor we recommend that as large a shim as possible is placed beneath the fixing screw's butterfly nut. During this process the position of the PFEIFER Super Waved Anchor should be secured by working it onto the reinforcement. Merely nailing it on is not sufficient to prevent leaning while the formwork is being filled or jolting.

Fig. 2: Flush installation

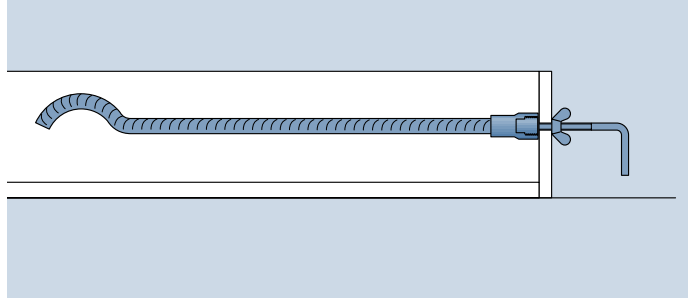

• **Flush installation (Fig. 2)**

For formwork installation that is level with the surface the PFEIFER Fixing Bolt is fixed directly to the PFEIFER Fixing Screw. In doing so, attention should be paid that the PFEIFER-Super Waved Anchor is lying flatly onto the formwork (Fig. 2) so that the matching PFEIFER-Super Lifter can lie on it in an optimum position. This method is only possible if subsequent flush and open Super Waved Anchor sockets do not cause any obstruction in the precast unit. It is not possible to close the opening with this installation.



Nailing on the recess disc can lead to risk of injury before and after the removal of the formwork. For this reason we recommend that the nail is snapped off or the disc is carefully removed immediately when the formwork is stripped.

Fig. 3: Recessed installation is recommended in the case of parallel shear pull or transversal pull

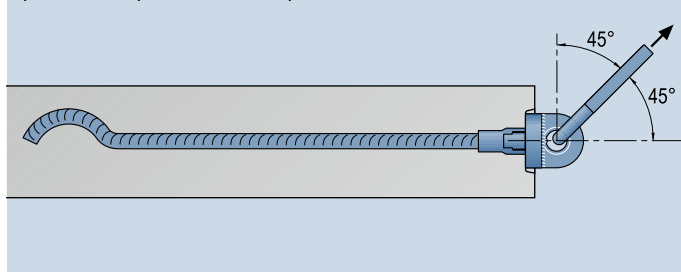
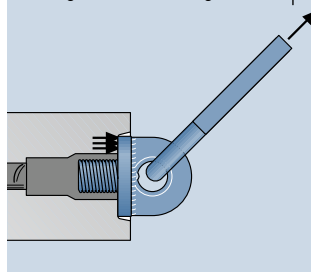

Fig. 4: Good contact pressure through even recessing



For lifting all precast units the PFEIFER-Super Waved Anchor system should be installed with the recess disc and the PFEIFER Fixed Screw (Fig. 3).

Only in this way is it possible to gain access to a level surface which is right-angled to the lifting anchor's longitudinal axis for the pressure plate (Fig. 4).

Due to its sturdy design, the PFEIFER Recess Disc which is made from steel ensures a long period of use.

Fig. 5: Neat finishing with the external cap

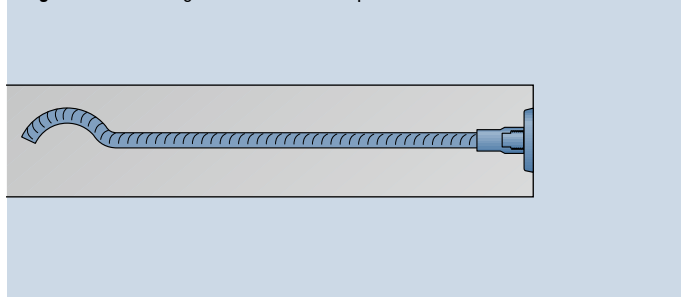

When the PFEIFER Recess Disc is used, it is possible to close the lifting anchor opening level to the surface after assembly. The PFEIFER External Cap is fixed to the PFEIFER Fixing Bolt on the PFEIFER-Super Waved Anchor. For this purpose, the recess disc is delivered with a hexagon socket head screw with which the PFEIFER Recess Disc is fixed to the PFEIFER Fixed Bolt (Fig. 5). Consequently, the recess disc closes off flush with the surrounding concrete. A stainless steel design is recommended in a corrosive atmosphere.

Enquiry

Order Please tick if applicable

PFEIFER SEIL- UND HEBETECHNIK GMBH
 Area of business BUILDING TECHNOLOGY
 Postfach 1754 · D-87687 Memmingen

Fax +49 (0) 83 31-937-342

ORDERER / ENQUIRER

| |
|---------------|
| Company |
| Street |
| Town Postcode |
| Contact |
| Telephone |
| Fax |

| |
|----------------------|
| Construction project |
|----------------------|

PFEIFER Super Anchor System

PFEIFER Super Waved Anchor



PFEIFER Super Lifter



Accessories for PFEIFER Super Anchor System



| Item | Quantity | Type Size | Description | Order no. | Load capacity kN |
|------|----------|-----------|-------------|-----------|------------------|
| | | | | | |
| | | | | | |
| | | | | | |
| | | | | | |
| | | | | | |
| | | | | | |
| | | | | | |
| | | | | | |

Please take the packing units into consideration

The order is based on PFEIFER's Conditions for Sales and Services with which you are familiar.

| |
|--|
| Delivery address |
| (only fill in if different than the order address) |
| |
| |

Date and signature

PFEIFER SEIL- UND HEBETECHNIK GMBH

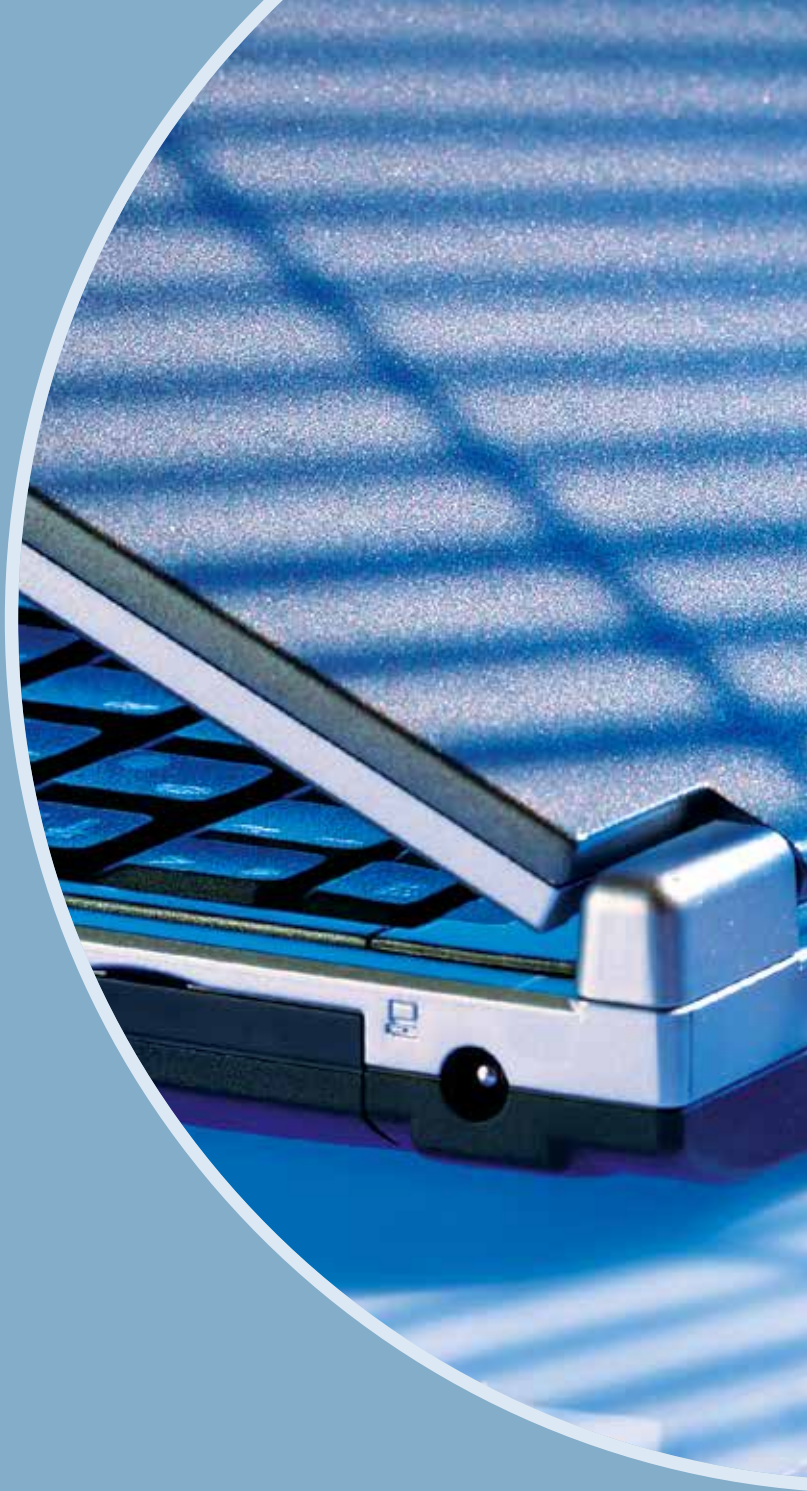

PFEIFER

International

Sales

+49 (0) 83 31-937-231

Technical Support

+49 (0) 83 31-937-345

export-bt@pfeifer.de

www.pfeifer.info/concrete-inserts