



New  
sizes!

## Bent Loop

The angle with power

**PFEIFER**



# Do precast slabs and angled elements have to be lifted safely and economically?

The economic limits are set very tightly when it comes to concrete elements. Nevertheless, there's no room for compromises on safety and use. Despite that, unsuitable and formally inadequate solutions are still often used in practice.



## Self-made lifting anchors

Made of reinforcing steel or prestressing cables are not permissible without verifications and tests. They do not conform to the EC Machinery Directive.

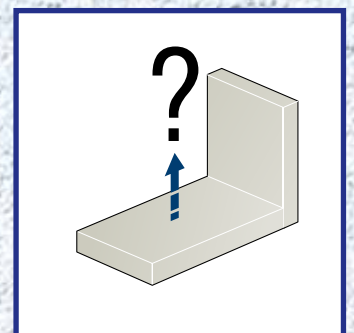
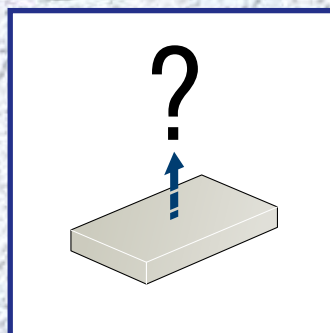
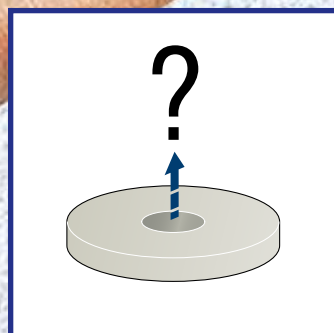
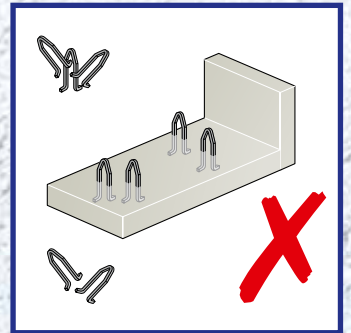

# PFEIFER Bent Loops help you to transport precast slabs and angled elements safely and cost-effectively

With a variety of possible applications, the new version of the PFEIFER Bent Loop enables the transport of the most diverse precast concrete elements - safely and in compliance with the directives.



## Economical use

- For flat elements and floor slab elements of all kinds
- Round and rectangular
- For angled elements and L-shaped retaining walls



## Technically versatile usability

- Straight pull
- Parallel shear pull
- Transversal shear pull for WS 0,8 to 2,4

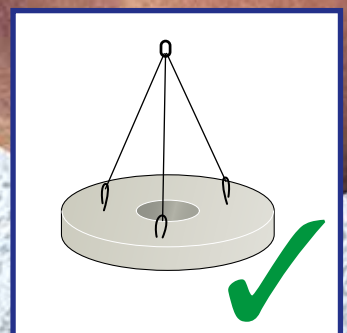
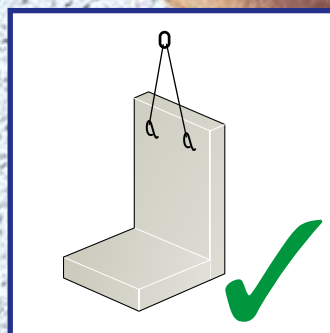
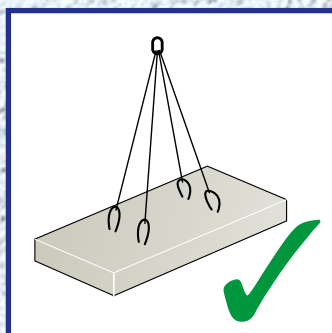
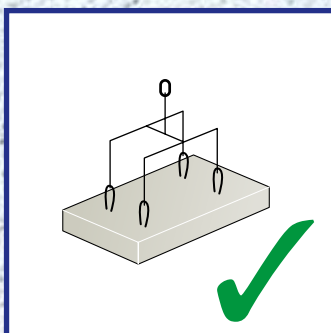

# The PFEIFER Bent Loop – strong thanks to performance, quality and economy



## **Tested for applications**

With slabs and angled elements



## **Reinforcement**

Ideally fastened via defined points



## **Optimised holding bracket**

Enables the most diverse methods of fastening by:

- Welding on (WS 0,8 to 2,4)
- Fixing with tying wire
- Fixing with cable ties, etc.



## **No additional reinforcement necessary**



## **Conforms to the EC Machinery Directive**

Taking into account the VDI/BV-BS Directive 6205



## **Made in Germany**



# PFEIFER Bent Loop for slabs and angled walls



**PFEIFER**

Bent Loop  
BS Anchor System

The PFEIFER Bent Loop was developed to be used as a lifting anchor for lifting concrete elements. Regular stresses are straight pull, parallel shear pull and transversal shear pull. The shape and the form of the holding bracket enable very simple installation and easy fixing to the reinforcement. Once the concrete has cured, a suitable suspension hook can be hooked into the protruding loop and the element can be transported safely.

### Advantages:

- Safe lifting
- simple installation
- secure fastening in the reinforcement
- no additional reinforcement
- colour coding.

### Material:

round strand rope, high strength, galvanized, Holding bracket, bare sheet steel

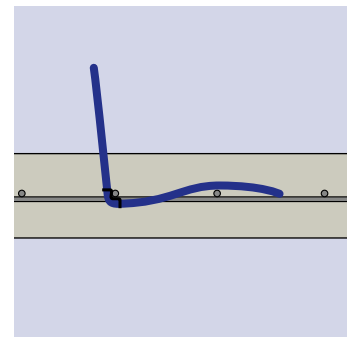
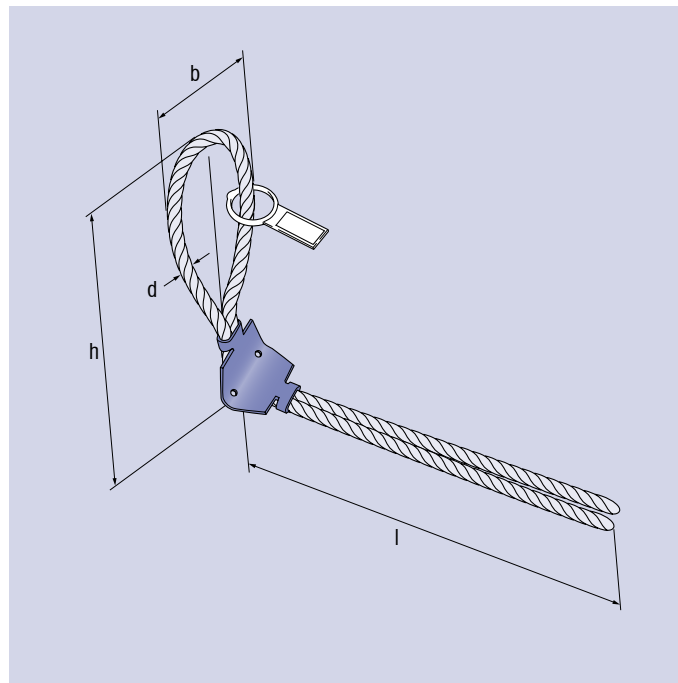

Type/Size	Ref. no.	b [mm]	d [mm]	l [mm]	h [mm]	Weight [kg/pc]
WS 0.8	<b>05.023.083.205</b>	~ 85	6	280	205	0.20
WS 1.6	<b>05.023.163.205</b>	~ 85	8	280	205	0.33
WS 2.4	<b>05.023.243.285</b>	~120	10	280	285	0.45

## Product description

Figure 1

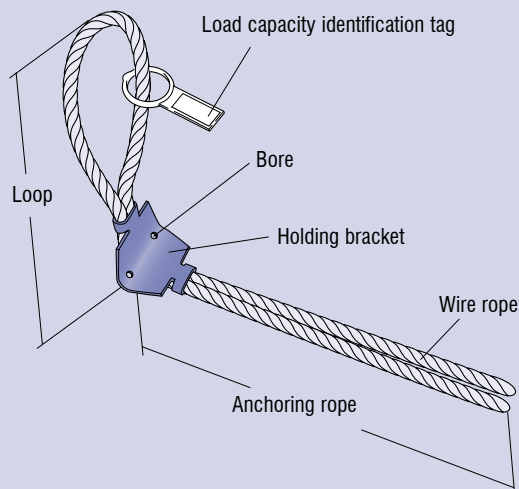

PFEIFER Bent Loops consist of a specially shaped holding bracket, a high-quality rope and an appropriately marked load capacity tag.

The holding bracket has two holes that can be used to fasten the loop to the reinforcement. The free ends are for anchoring in the concrete. After casting into the concrete, the loop protrudes above the concrete surface and can be used for attachment when lifting or transporting the precast concrete element.

Table 1: Colour coding

Type/Size	Colour
WS 0.8	Pure white
WS 1.6	Light pink
WS 2.4	Anthracite grey

## Safety

In defining safety, it is assumed that the lifting anchors are used in precast elements manufactured in a factory with continuous monitoring.

In accordance with VDI/BV-BS 6205, the working coefficients are as follows:

- Full section failure:  $\gamma_s = 3,0$
- Steel rope failure:  $\gamma_{seil} = 4,0$
- Concrete failure:  $\gamma_c = 2,1$
- Dynamic factor (load side):  $\psi_{dyn} = 1,3$

## Intended use

straight pull 0°

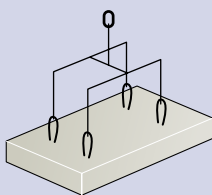

Figure 2

parallel shear pull

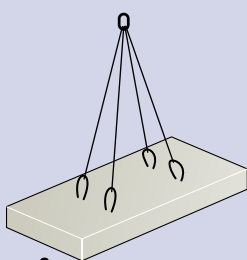

Figure 3

Parallel shear pull

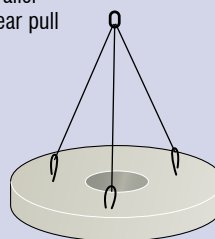

Figure 4

transversal shear pull

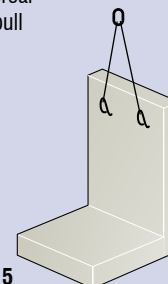

Figure 5

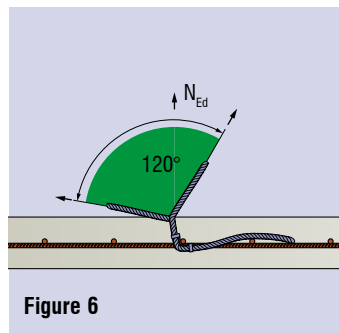

Figure 6

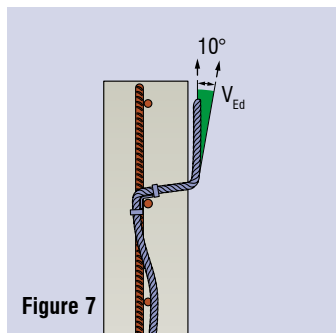
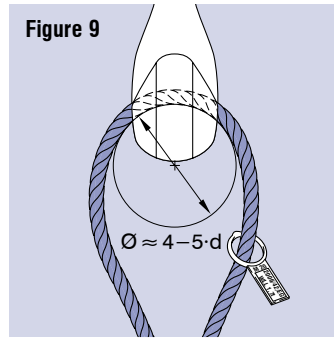
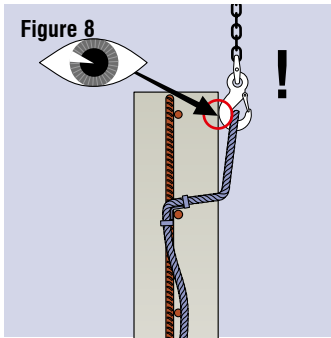

Figure 7

The PFEIFER Bent Loop is intended for the lifting and transport of plane and angled precast concrete elements. In regular use the Bent Loops may be subject to straight pull up to an angle of inclination of 30° from the perpendicular only in the direction of the free rope ends or with transversal shear pull perpendicular to the component level.

## Intended use



### Warning:

The deflection diameters shown in fig. 9 must be complied with. Deviating diameters lead to reduced system safety, falling and deadly danger!



### Caution:

Only suspension hooks of a size suitable for the Bent Loop may be used. Overly large hooks can become wedged and exert additional forces on the Bent Loop. This reduces the residual strength.

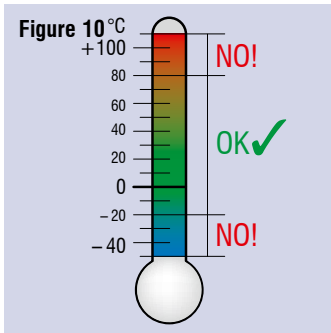

## Dimensioning

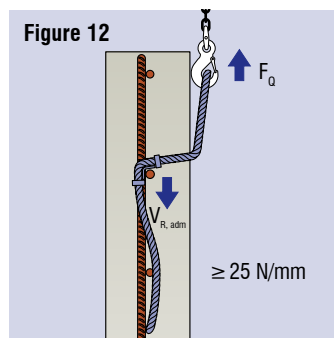
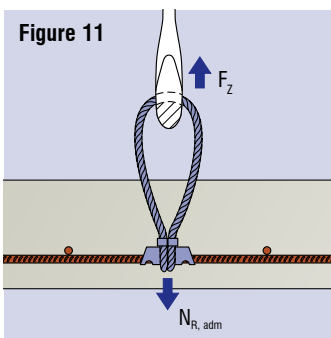

$$\frac{F_z}{N_{R,zul}} \leq 1,0$$

$$\frac{F_Q}{V_{R,zul}} \leq 1,0$$



### Notice:

Dimensioning by a trained technical person (expert) according to VDI/BV-BS 6205

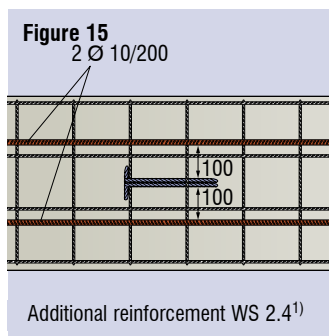
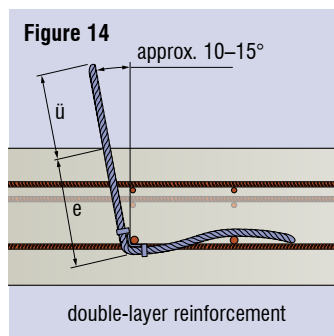
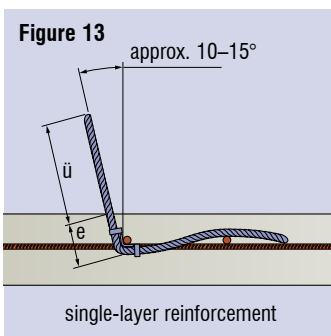

Additional reinforcement WS 2.4<sup>1)</sup>

Table 2: Structural element dimension, resistances and reinforcement

Type/Size	$N_{R,adm}$ 0-30° [kN] $\geq 15 \text{ N/mm}^2$	$V_{R,adm}$ 90° [kN] $\geq 25 \text{ N/mm}^2$	Minimum reinforcement	Additional reinforcement	Minimum structural element thickness $d$ [mm]	Overlap $\ddot{u}$ [mm]	Dimension $e$ [mm]	Minimum distance from edge $c_1$ [mm]	Minimum distance from edge $c_2$ [mm]	Minimum distance $s$ [mm]
WS 0.8	6	7	R188 <sup>2)</sup>	-	100	145	60	240	240	480
WS 0.8	8	7	2 x R188 <sup>2)</sup>	-	120	120	85	240	240	480
WS 1.6	11	12	2 x R188 <sup>2)</sup>	-	120	120	85	240	240	480
WS 2.4	14	14	2 x R188 <sup>2)</sup>	-	150	170	115	240	240	480
WS 2.4	24	18	2 x R188 <sup>2)</sup>	2 $\varnothing 10\text{mm}^1)$	200	120	165	240	390	480



### Notice:

<sup>1)</sup> For the Bent Loop WS 2.4 with a permissible resistance of 24 kN an additional reinforcement 2  $\varnothing 10$  mm is to be installed in the upper reinforcement layer parallel to the anchor axis (fig. 15).

<sup>2)</sup> across section: longitudinal direction = 188 mm<sup>2</sup>/m, transverse direction = 113 mm<sup>2</sup>/m

## Dimensioning

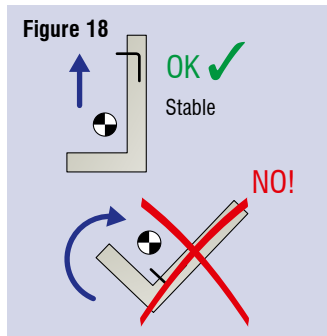
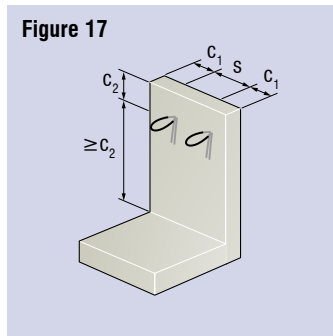
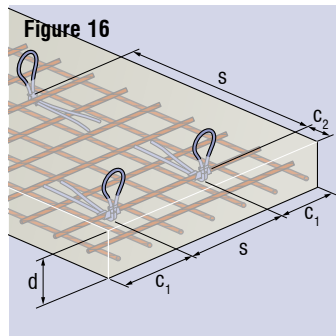

**Notice:**  
Always install the anchors above the centre of gravity, otherwise there is a danger of tipping during transport!

## Installation

**Notice:**  
Installation only by trained expert personnel:  
– use only original PFEIFER Bent Loops  
– adhere to all installation rules  
– fasten the Bent Loop in such a way that its position cannot change  
– compact the concrete carefully, paying attention to the built-in components

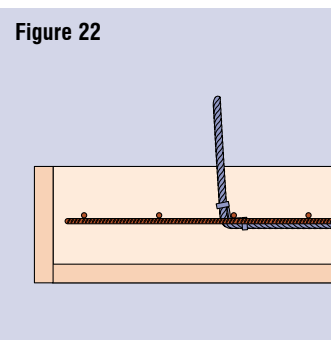
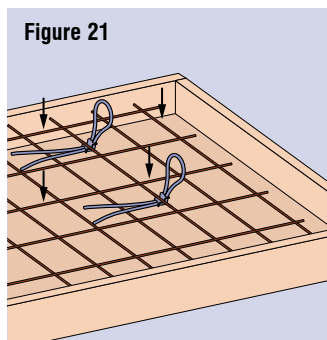
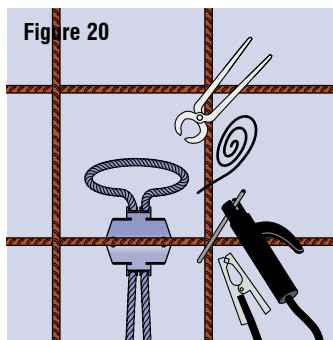
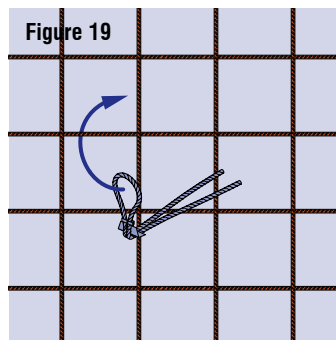

### Fixing the loop

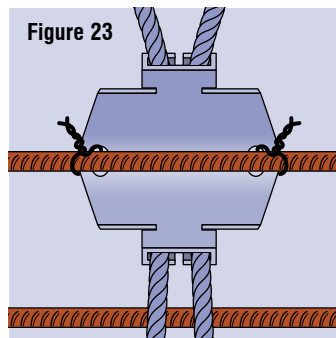

**Notice:**  
The loop can be fastened by  
– tie-wire  
– spot weld  
– cable tie.  
The holes should be used for fixing with cable ties and tie-wire.

### Fixing with a spot weld

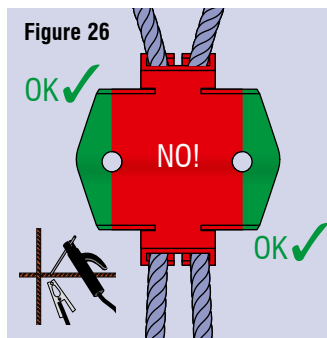
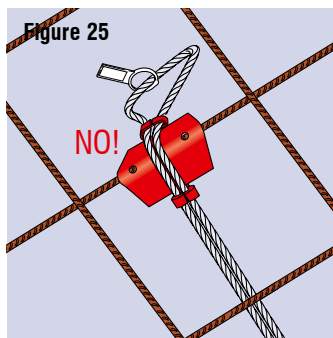
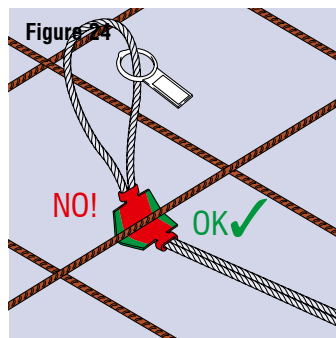

**Caution:**  
A spot weld for fixing the loop may only be placed in the areas marked in figs. 24, 25 and 26. The areas marked in red in figs. 24, 25 and 26 may not be used for this.



# PFEIFER Bent Loop for slabs



**PFEIFER**

Bent Loop  
BS Anchor System

The PFEIFER Bent Loop was developed to be used as a lifting anchor for lifting concrete elements. Regular stresses are straight pull, parallel shear pull and transversal shear pull. The shape and the form of the holding bracket enable very simple installation and easy fixing to the reinforcement. Once the concrete has cured, a suitable suspension hook can be hooked into the protruding loop and the element can be transported safely.

#### Advantages:

- Safe lifting
- simple installation
- secure fastening in the reinforcement
- no additional reinforcement
- colour coding.

#### Material:

round strand rope, high strength, galvanized, Holding bracket, bare sheet steel

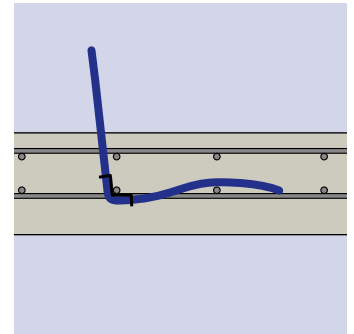
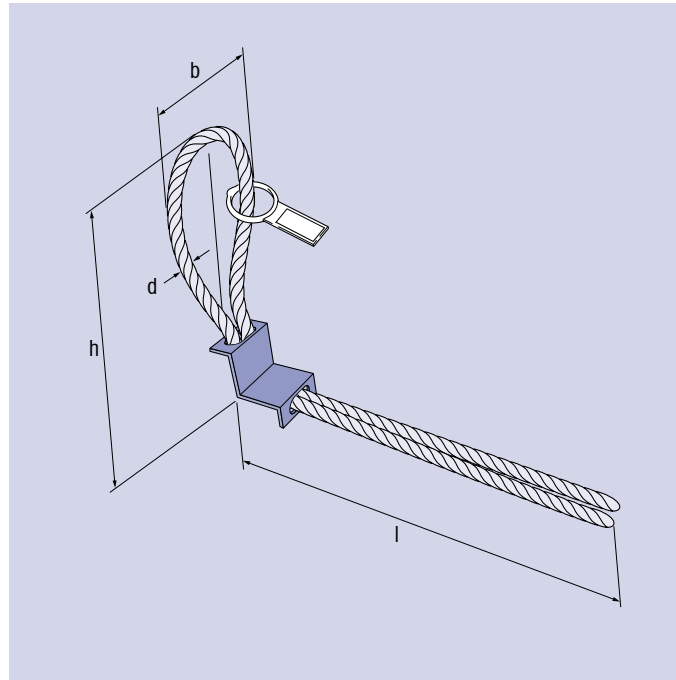

Type/Size	Ref. no.	b [mm]	d [mm]	l [mm]	h [mm]	Weight [kg/pc]
WS 4,0	<b>05.023.403.209</b>	140	13	320	290	0,94
WS 5,2	<b>05.023.523.320</b>	150	14	320	320	1,13

## Product description

Figure 1

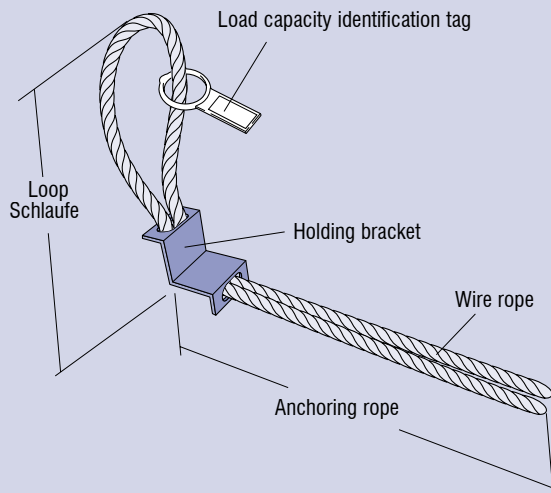

PFEIFER bent loops consist of a specially shaped holding bracket, a high-quality rope and an appropriately marked load capacity identification tag. The holding bracket is intended for the correct alignment of the loop and for fixing to the reinforcement with wire or cable ties. The free ends are for anchoring in the concrete. In the cast in concrete state, the loop protrudes above the concrete surface and can be used for attachment when lifting or transporting the precast concrete element.

Table 1: Colour coding

Type/Size	Colour
WS 4,0	emerald green
WS 5,2	curry

## Safety

In defining safety, it is assumed that the lifting anchors are used in precast elements manufactured in a factory with continuous monitoring. In accordance with VDI/BV-BS 6205, the working coefficients are as follows:

- Full section failure:  $\gamma_s = 3,0$
- Steel rope failure:  $\gamma_{seil} = 4,0$
- Concrete failure:  $\gamma_c = 2,1$
- Dynamic factor (load side):  $\Psi_{dyn} = 1,3$

## Intended use

straight pull 0°

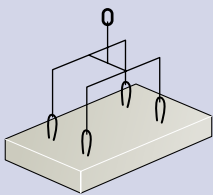

Figure 2

parallel shear pull

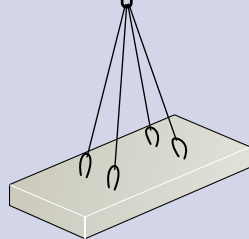

Figure 3

Parallel shear pull

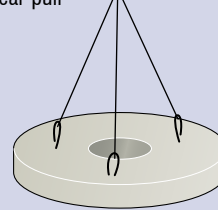

Figure 4

transversal shear pull

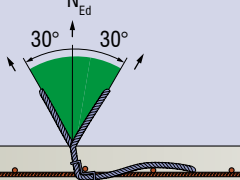
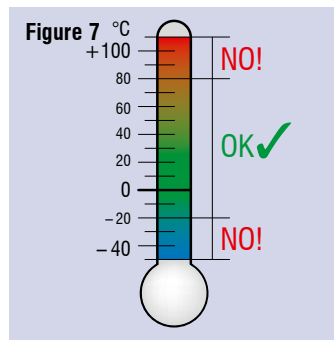
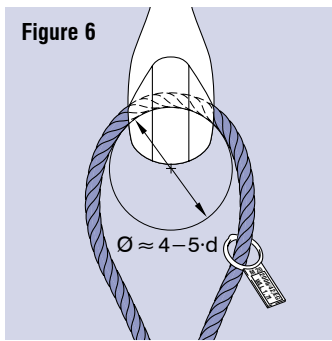

Figure 5

The PFEIFER bent loop is intended for the lifting and transport of plane precast units. In regular use the bent loops may be loaded straight or up to an angle of inclination of 30° from the perpendicular only in the direction of the free rope ends.

## Intended use



### Warning:

The deflection diameters shown in fig. 9 must be complied with. Deviating diameters lead to reduced system safety, falling and deadly danger!



### Caution:

Only suspension hooks of a size suitable for the Bent Loop may be used. Overly large hooks can become wedged and exert additional forces on the Bent Loop. This reduces the residual strength.

## Dimensioning

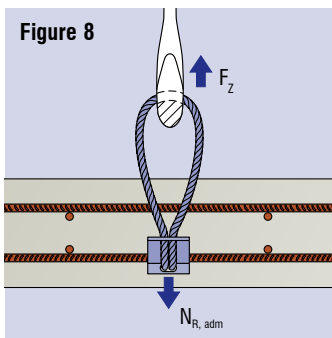

$$\frac{F_z}{N_{R,zul}} \leq 1,0$$



### Notice:

Dimensioning by a trained technical person (expert) according to VDI/BV-BS 6205

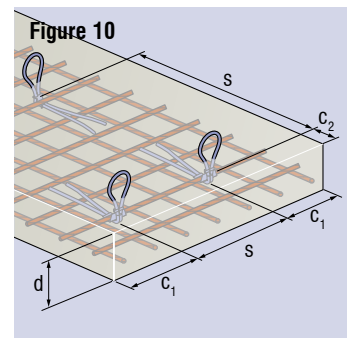
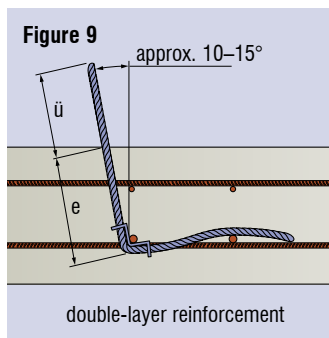

Table 2: Structural element dimension, resistances and reinforcement

Type/Size	$N_{R,adm}$ 0-30° [kN] ≥ 15 N/mm <sup>2</sup>	Minimum reinforcement	Minimum structural element thickness d [mm]	Overlap ü [mm]	Dimension e [mm]	Minimum distance from edge $c_1$ [mm]	Minimum distance from edge $c_2$ [mm]	Minimum distance s [mm]
WS 4.0	40	2 x R257	200	120	170	450	450	900
WS 5.2	52	2 x R335	230	120	200	600	600	1200

## Installation



### Notice:

Installation only by trained expert personnel:

- use only original PFEIFER Bent Loops
- adhere to all installation rules
- fasten the Bent Loop in such a way that its position cannot change
- compact the concrete carefully, paying attention to the built-in components

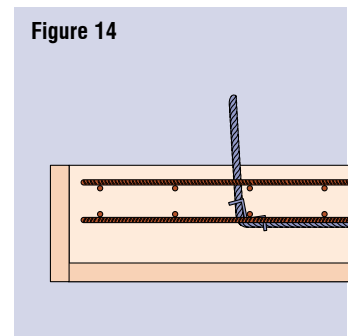
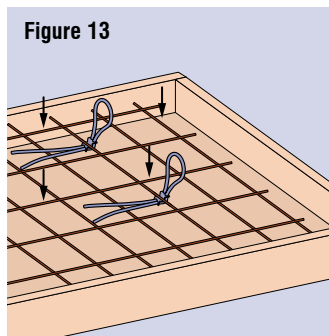
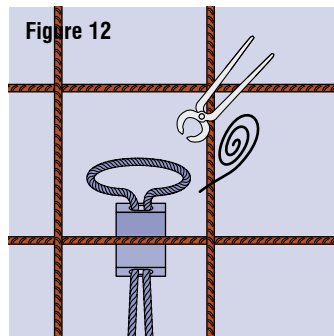
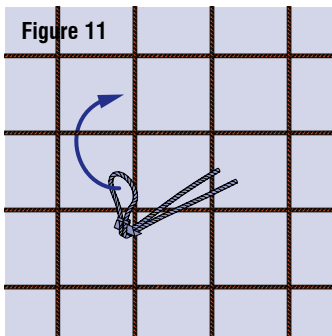

## Installation

### Fixing the loop



#### Notice:

The loop can be fastened by

- tie-wire
- cable tie.

## Incorrect use and discarding time

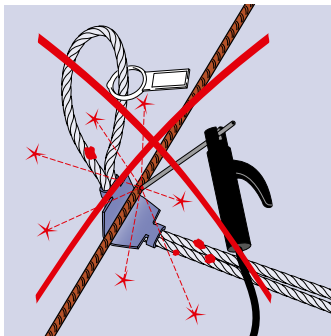
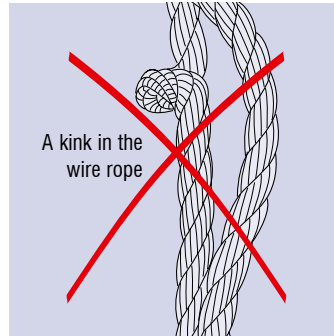
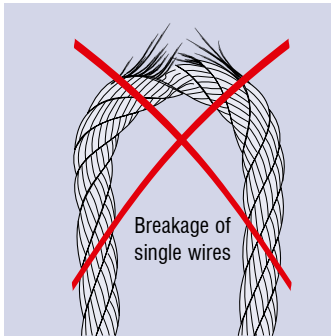

#### Caution:

- Incorrect installation and use can result in reduced carrying capacities. This results in the risk of a fall and a hazard to life and limb. Lifting anchor systems must be used only in accordance with the instructions for installation and use and only by suitable trained personnel
- The complete Bent Loop must be replaced if there is welding sputter/beads on the rope. A loop damaged in this way may no longer be used! Danger to life!



#### Warning:

- All changes or modifications to the anchor are impermissible or may only be carried out by the manufacturer. Each change or modification can lead to a reduction in safety extending to the failure of the anchor and the falling of the structural element.
- The use of the anchor system for lashing the structural element during transport is not permissible. Use these anchor systems only for lifting and moving the stated precast concrete elements!

## Storage

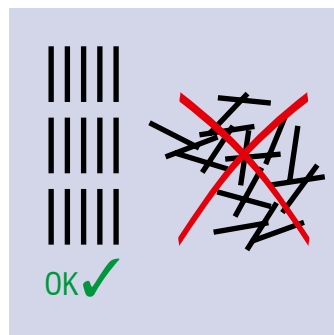
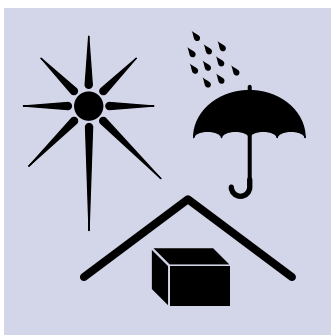

#### Notice:

Ensure damage-free storage.

Store the PFEIFER Bent Loops as far as possible protected in a dry place. There is a risk of corrosion if there are large temperature changes or wet conditions in combination with road salt or sea water!

## PFEIFER-Schachtabhebersystem SAS

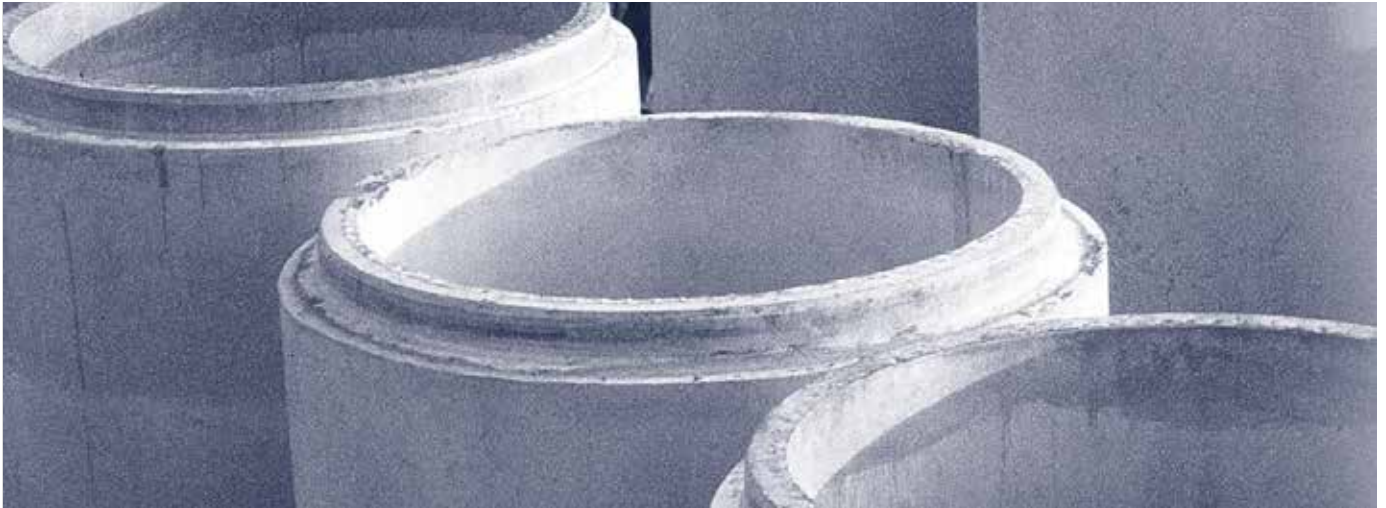

### Product description

The PFEIFER SAS System demonstrates the versatility of the PFEIFER lifting anchors. Proven PFEIFER lifting anchors in combination with a specially developed lifting loop form the basis of the SAS System, which is used for the lifting and movement of pipes and manhole elements. Like all PFEIFER Systems, safety is the utmost priority here and takes the form of a self-contained system developed in compliance with the VDI/BV-BS 6205 directive. The anchors consist of special-grade precision steel tubes with anchor bolt or anchor plate, while the lifting device consists of a flat material and high-strength screws, combined with a flexible steel wire rope.

### + Advantages

- efficient and flexible transport of manholes
- attachment bolt cannot be lost
- optimum range of products for all practically relevant applications
- original PFEIFER colour coding for handling without mix-ups

### 🏭 Product range

- SAS Lifting Anchor for Manholes
- SAS Lifting Device
- Accessories

### § Directives

- design and production of all SAS Manhole Lifting System components and installation instructions in compliance with the EC Machinery Directive
- all products conform to VDI/BV-BS 6205 and are thus CE-compliant
- safe work equipment as defined in health & safety legislation according to BetrSichV (Operational Safety Ordinance)

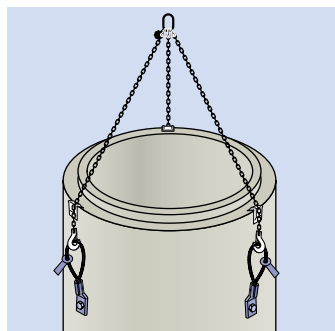

## PFEIFER BS Anchor System



### Product description

The PFEIFER BS Anchors are the ideal lifting anchors if heavy structural elements have to be transported inexpensively. Special heavy-duty anchors have already been realised with load-bearing capacities of up to 180 t. The BS Anchors consist of an oval-bent, high-strength quality steel rope, which is swaged with a special ferrule – with the experience of a rope making dynasty stretching back 436 years.

It is suitable for solid, compact structural elements as well as slender prestressed beams. The transport of bridge elements and raker beams for sports stadia is thus no problem. The additional use of a lifting and turning device can be dispensed with, since attachment is made directly to the suspension gear hook or shackle. The part of the PFEIFER BS Anchor that protrudes above the surface can be cut off directly after use. Associated system components with an optional recessed installation are the BS Hook and the BS Moulding Insert.

### + Advantages

- standard heavy duty anchor
- direct attachment to the suspension hook, without expensive lifting devices
- inexpensive alternative for the transport of precast elements
- original PFEIFER colour coding for handling without mix-ups
- wide range of applications – already realised as a custom anchor up to 180 t

### 🏭 Product range

- BS Lifting Anchor up to 180 t
- BS Lifting Device
- Accessories

### § Directives

- design and production of all BS Anchor System components and installation instructions in compliance with the EC Machinery Directive
- all products conform to VDI/BV-BS 6205 and are thus CE-compliant
- safe work equipment as defined in health & safety legislation according to BetrSichV (Operational Safety Ordinance)

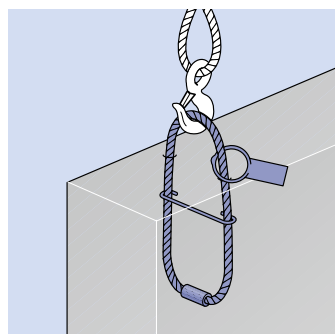

## PFEIFER Custom Lifting Anchor



### Product description

The search for solutions to numerous problems leads customers to the PFEIFER Custom Lifting Anchors, such as the PFEIFER Lifting Box, which was developed for the safe transport of manhole elements, and the PFEIFER Bent Loop for the lifting and transport of concrete floors and angled elements. And that's not all – the PFEIFER LB Anchor, which serves as a lifting anchor for storey-high wall panels made of lightweight aggregate concrete, and the PFEIFER Masonry Anchor, which is pushed through the hollow space of the stones and grouted after completion of the brick element, are also so-called custom lifting anchors.

### + Advantages

- the solutions to customer problems – the right anchor for every application
- economic alternatives for special applications
- experience in development and proven PFEIFER quality

### 🏭 Product range

- PFEIFER Lifting Box
- PFEIFER Bent Loop
- PFEIFER LB Anchor
- PFEIFER Masonry Anchor

### § Directives

- design and production of all custom anchor components and installation instructions in compliance with the EC Machinery Directive
- all products conform to VDI/BV-BS 6205 and are thus CE-compliant
- safe work equipment as defined in health & safety legislation according to BetrSichV (Operational Safety Ordinance)

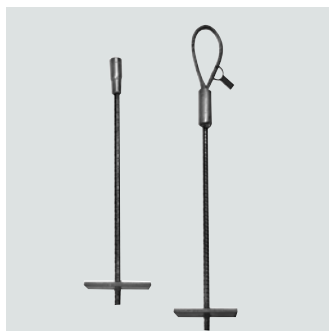



# PFEIFER

International

Sales

+49 (0) 83 31-937-231

Technical Support

+49 (0) 83 31-937-345

[export-bt@pfeifer.de](mailto:export-bt@pfeifer.de)

[www.pfeifer.info/concrete-inserts](http://www.pfeifer.info/concrete-inserts)

Images: Fotolia